

PRBMD02 tiny BT5 ready module

Data sheet version 0.9

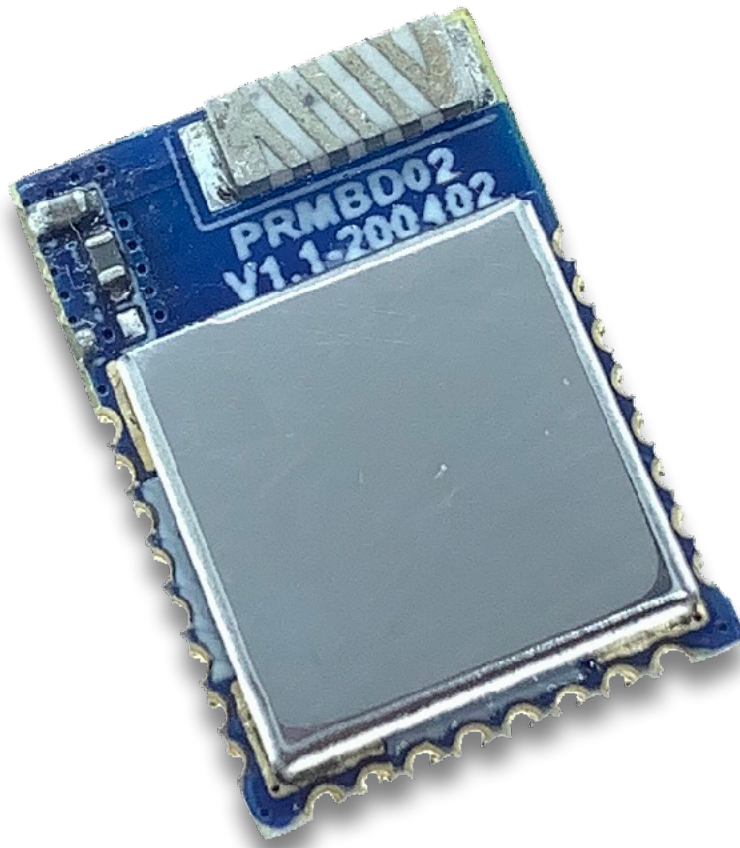

Disclaimer

Liability Disclaimer

K-Solution Consulting Co. Ltd reserves the right to make changes without further notice to the product to improve reliability, function or design. K-Solution Consulting Co. Ltd does not assume any liability arising out of the application or use of any product or circuits described herein.

Life Support Applications

K-Solution Consulting Co. Ltd's products are not designed for use in life support appliances, devices, or systems where malfunction of these products can reasonably be expected to result in personal injury. K-Solution Consulting Co. Ltd customers using or selling these products for use in such applications do so at their own risk and agree to fully indemnify K-Solution Consulting Co. Ltd for any damages resulting from such improper use or sale.

Introduction

Base on PHY+ Microelectronics' PHY6222 Bluetooth 5 ready core chip, PRBMD02 BT 5 ready module provides a reliable and easy BT5 solution, allowing user, even without any RF design experience, brings their their product or system, embedded with BT5 feature, to market in time.

Integrated with almost all peripheral components, such as RF matching network, Antenna, 16MHz Crystal, 32768Hz RC, and DC/DC inductor, which saves engineer resource from hardware design for BLE.

PRBMD02 provides a small form factors which is suitable for different applications, with GPIO count, provides high flexibility to user.

PRBMD02 is FCC, CE and Telec * certified module, which reduces customer's resource for qualification and allows product to be time to market.

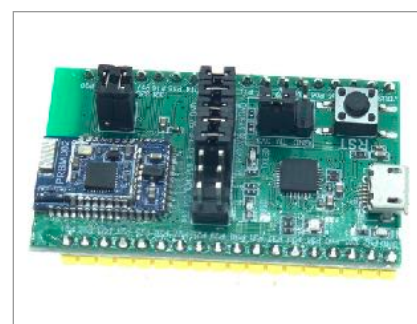
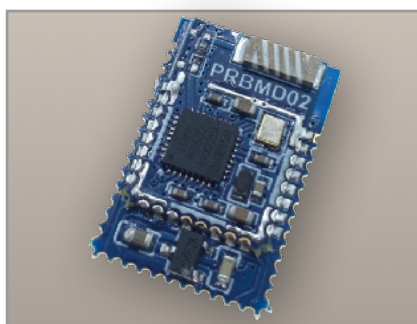
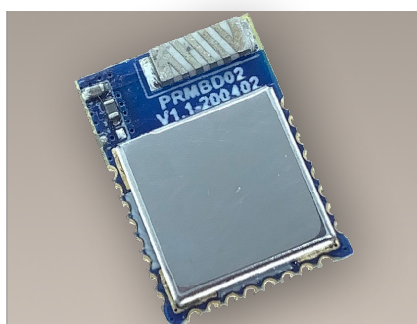

Applications

- Phone accessories
- Computer peripherals
- CE remote controls for TV, STB and media systems
- Beacons
- Proximity and security alert tags
- Sports and fitness sensors
- Healthcare and lifestyle sensors
- Game controllers
- Home Automation
- Smart RF tags for tracking and social interaction

*In progress

Hardware information

Features

- 32bit Cortex™-M0 processor with 2.4GHz wireless
 - Single-scale 32-bit multiplier
 - Nested Vector Interrupt Controller (NVIC)
 - Up to 48MHz
 - ARMv6M architecture, Thumb ISA but no ARM ISA
 - Up to 32 interprets embedded NVIC
- Sleep/deep sleep mode
- On board chip antenna
- On board 16MHz crystal
- Internal 32K RC network
- On board DC/DC converter
- 128KB Flash, 64KB SRAM, 8K cache
- Small form factor: 10 x 14mm
- High GPIOs count : up to 19
- Soft configurable interfaces: PWM (6), PDM (2), I2C (2), SPI (2), UART (2)
- JTAG for debugging
- Up to seven channels 12bit ADC
- Programmable Gain Amplifier (PGA)
- Bluetooth v5.0 compliant Protocol Stack (BLE)
- Low power consumption ($1\mu\text{A}$ when sleep; 0.3μ when OFF)
- Supports SIG_Mesh feature: Friend node, Low Power node, Proxy node and Relay node
- Sensitivity up to -103dBm @125Kbps
- Tx power from -20 to +10dBm
- FCC, CE and TELEC certification (in progress)

Pin assignment

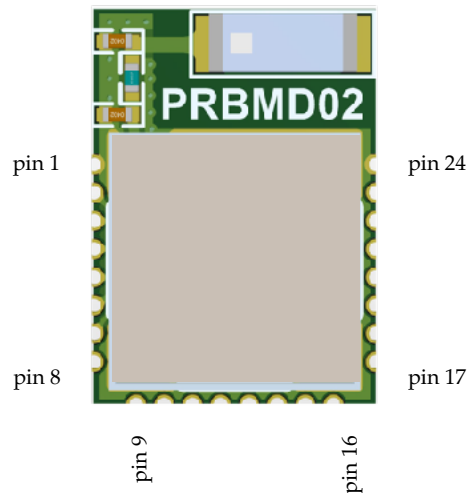

pin	name	Description	Alternative
1	GND	Power ground	
2	P23	GPIO	1. ADC input 1; 2. Mic bias
3	P24	GPIO	ADC input 2
4	P25	GPIO	ADC input 8
5	P31	GPIO	
6	P32	GPIO	
7	P33	GPIO	
8	P34	GPIO	
9	P00	GPIO	
10	P01	GPIO	
11	P02	GPIO	SWD debug data in
12	P03	GPIO	SWD debug clock
13	TM	Mode select pin	
14	P09	GPIO	
15	P10	GPIO	
16	RST	RESET	
17	VDD	VDD, 1.8 - 3.6V	
18	P14	GPIO	ADC input 3
19	P15	GPIO	1. ADC input 4; 2. MIC bias output
20	P16	GPIO	32768 oscillator in
21	P17	GPIO	32768 oscillator out
22	P18	GPIO	1. ADC input 7; 2. PGA negative input
23	P20	GPIO	1. ADC input 9; 2 PGA positive input
24	GND	GND	

Dimension

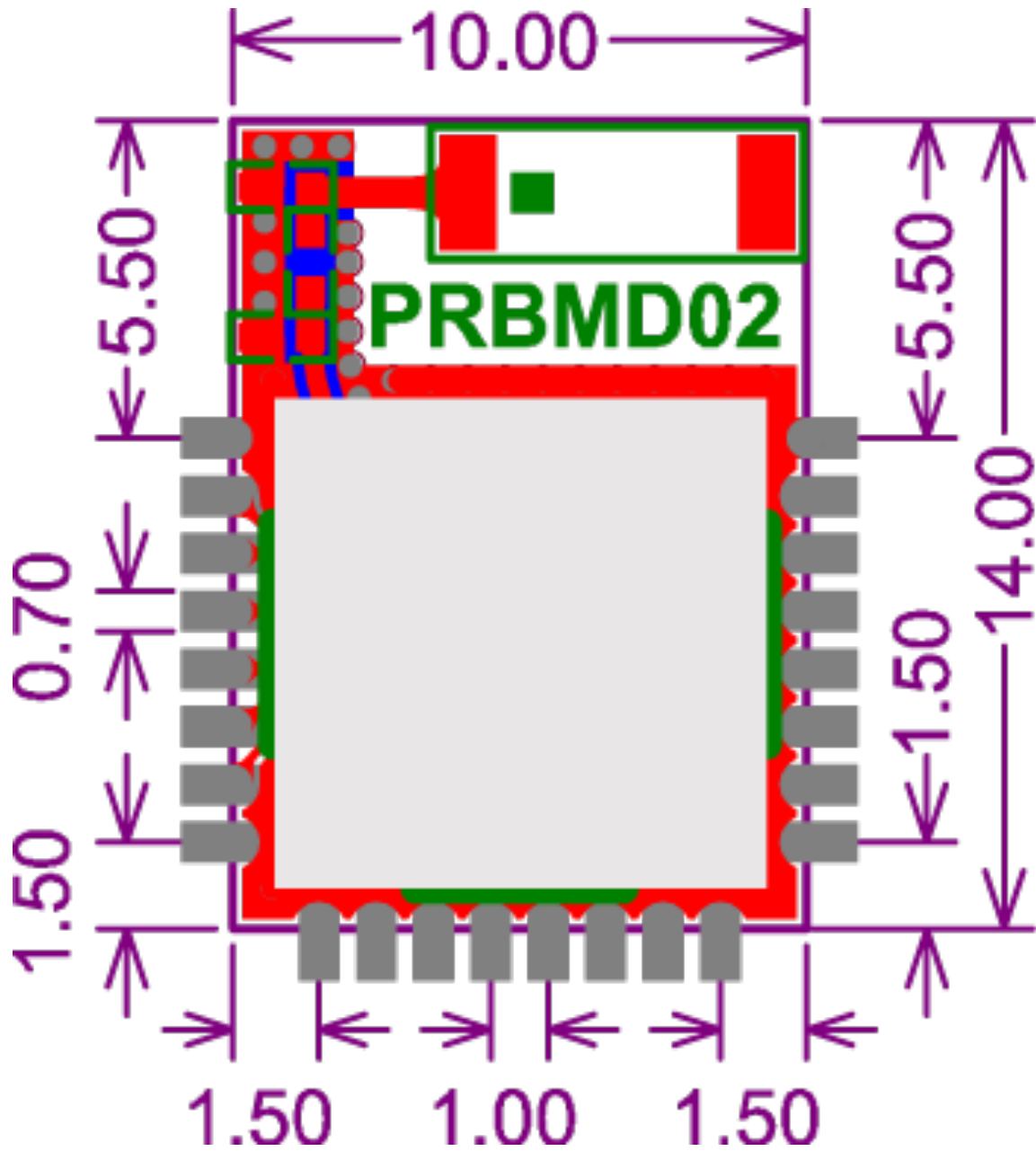

Unit: mm

thickness: 3mm

Electrical Specification

	Description	Typical
General	Operation voltage	2.5V to 6V DC
	Operation current	Advertising: Average - 3mA; Max peak - 9mA Connected Average - 3.18mA; Max peak - 9mA
	SLEEP mode current * needed firmware activation	Sleep mode: 1uA, with 32768Hz RTC
	OFF mode current	0.3uA
	Microcontroller	32-bit ARM Cortex M0, PHY6222
	GPIO	19 configurable
	Oscillators	16MHz crystal oscillator 32kHz RC oscillator (internal)
	Digital I/O	X2 Hardware SPI master UART
	Operation temperature	-20 to 85C
	RF	Frequency band
Modulation		GFSK
Data rate		250kbps, 1 Mbps, 2 Mbps
TX Power		-20 to +10dBm in 4dB steps
Sensitivity		-97dBm @ 1Mbps Bluetooth LE -103dBm @125kbps Bluetooth LE
RF Range (indoor)		100m

Table 1 Electrical Specification

To be confirmed

Reset the module

A low signal will reset the module, and the timing is illustrated as following:

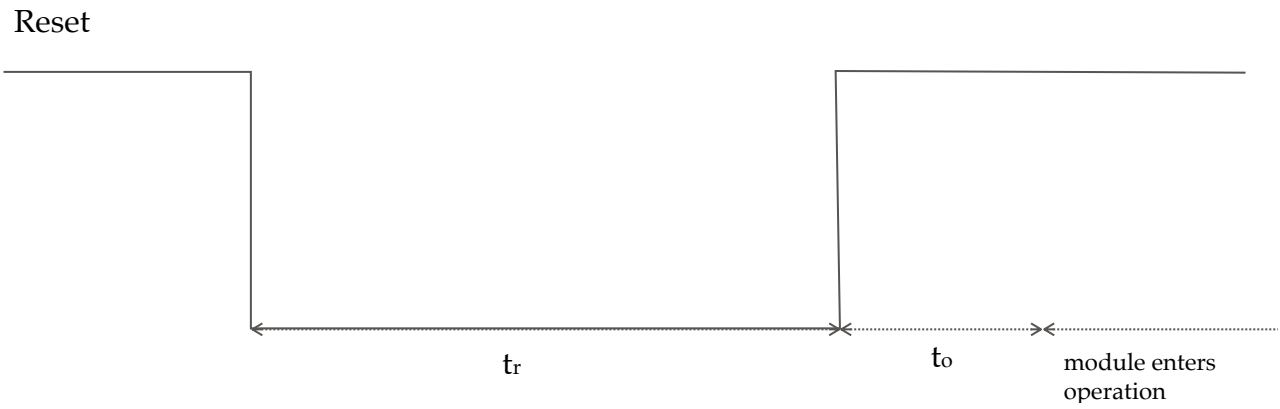

$t_r = \text{at least } 1\mu\text{s}$
 $t_o = 500\mu\text{s}$

The clock

Main clock

PRBMD0x embeds with a 16MHz main oscillator, and it is software configurable up scale to higher internal frequency: 32M, 48M, 64M or 96MHz. By default it is not up scaled.

RTC

If 32.768kHz crystal is not installed (pin P16 and P17), internal RC oscillator circuit can be then enable by firmware and be use as real time clock. This internal RC oscillator circuit will be calibrated periodically. External 32.768KHz circuit is illustrated as below:

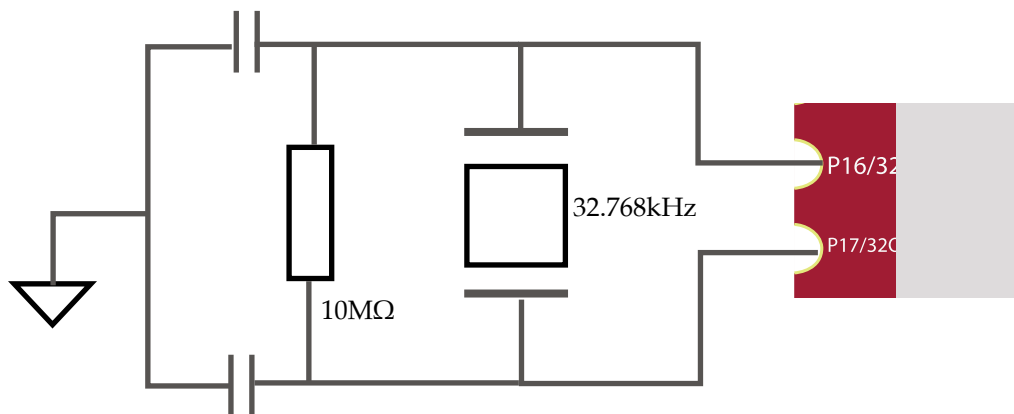

Using external crystal as RTC

Firmware programming

User is able to program their own developed firmware (with SDK) into PRBMD0x. The programming procedure is as following, programming software, PhyPlusKit.exe (for window) must be pre-installed, and UART-USB dongle may be needed:

1. Connect TM pin (pin 10) to 3.3V
2. Connect Tx and Rx (P09 and P10) pin to UART dongle
3. On PhyPlusKit, select the proper COM port and Baud Rate (default: 115200)
4. Click Erase to erase current firmware in PRBMD02
5. Load the firmware and click Write to program into PRBMD02
6. Connect TM pin to low level and apply reset. New firmware then starts to operate.

GPIO and interfaces

Every GPIO can be configured as Input, Output and Interrupt, and can also be configured as weak pull-up, strong pull-up, weak pull-low or floating mode.

Except ADC, all interfaces are possible to map to different GPIOs by software. The interface including:

1. I2C: it supports 100KHz and 400KHz modes, 7-bit and 10-bit address
2. I2S: either master or slave mode can be enabled
3. UART: Asynchronous Rx/Tx, up to almost 1Mbps, supports parity and 9 bit-data
4. PWM: 6 channels PWM is multiplex with GPIO, and the frequency is base on the main clock (16MHz) as the following equation:

$$\text{Freq_PWM} = 16\text{MHz} / (\text{N_prescaler} \times \text{N_top_count});$$

where the value in N_top_count register controls the frequency and the Duty cycle is controlled by the following equation:

$$\text{Duty_cycle_PWM} = \text{N_threshold} / \text{N_top_count}$$

where the value in N_threshold, together with N_top_count, control the duty cycle

5. Quadrature decoder: it can interface and decode signal from quadrature-encoded sensor, both mechanical and optical sensors. Input debounce filters is included.
6. Keyscan: it supports up to 16 rows by 18 columns key matrix. Multi-key-press support and de-bounce time is configurable.
7. Analog to Digital converter (ADC) : Up to 10 12-bit SAR ADC, and two inputs are with PGA, which provides a software configurable 0 to 42dB with 3dB steps.

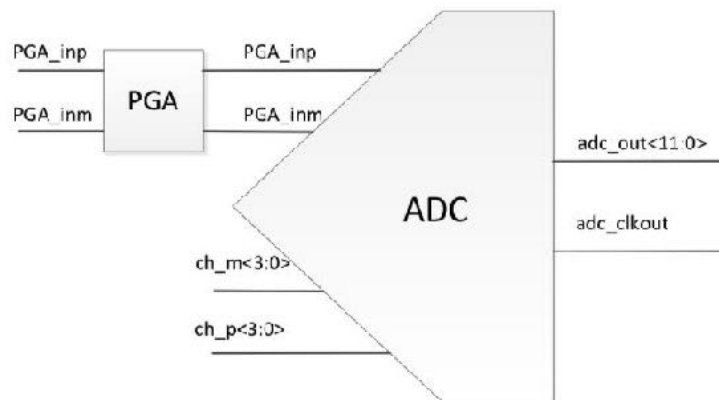

8. PGA provides 42dB gain range from 0dB to 42dB in 3dB steps.

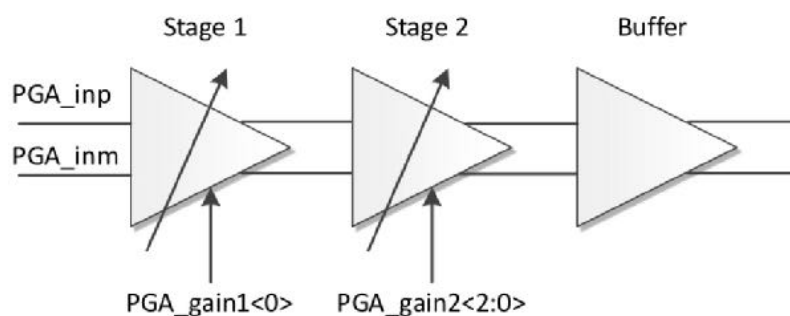

RF characteristic

PRBMD02 RF characteristic is illustrated as following:

2.45GHz

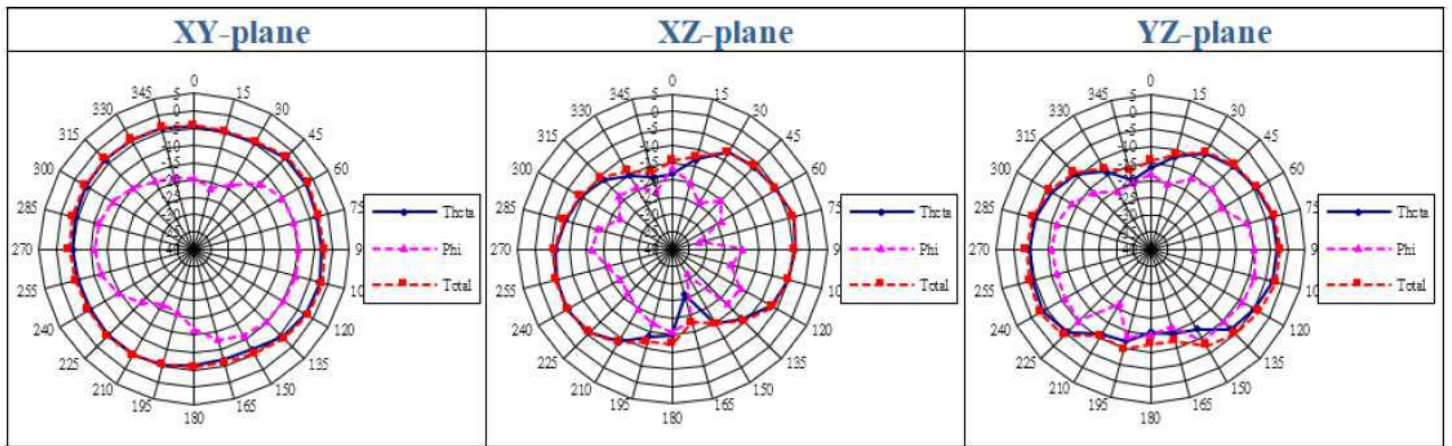
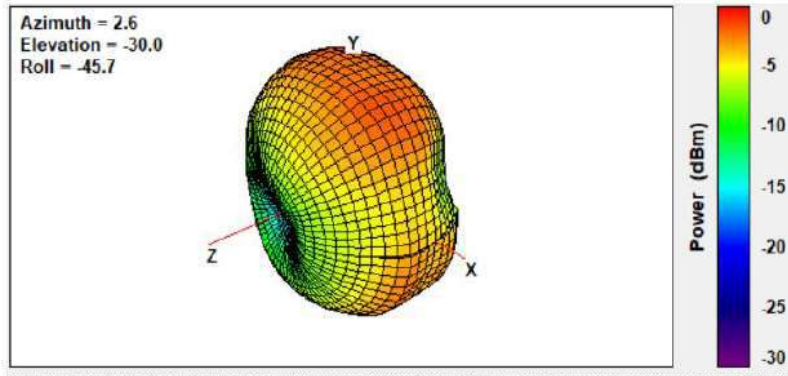

PRBMDxx family comparison

	PRBMD00	PRBMD02
Core chip	Cortex™ -M0	Cortex™ -M0 with SWD
Dimension	12x18mm	10x14mm
# of GPIO	33 GPIOs	19 GPIOs
Operation voltage	2.5 - 6V	1.8-3.6
Flash	512KB	128KB
SRAM	138KB	64KB
ROM	128KB	96KB
Cache	N/A	8KB
e-fuse	N/A	256bit
ADC	8 channel, 12 bits	7 channels, 12 bit
PGA	N/A	1
PWM	6 channels	6 channels
I2S	4 channels	N/A
SPI	2 channels	2 channels
I2C	2 channels	2 channels
UART	1 channels	2 channels
Current (Sleep, OFF)	2uA, 0.8uA	1uA, 0.3uA
Tx Power	-20 to +10dBm in 4dB steps	-20 to 10dBm in 3dB steps
Sensitivity		
Operation temperature	-10 to 60C	

To be finalised

Firmware information

Default firmware

PRBMD02 comes with default UART-BT firmware, allowing user able to enable their product with BT feature without any extra engineer resources. The firmware basic feature is to tunnel data between UART port and Bluetooth device (Transparent mode). User can develop their own firmware by SDK as well if default firmware is not applicable.

AT-CMD and Transparent Modes

The firmware contains two modes: AT-CMD mode and Transparent mode. In AT-CMD mode, PRBMD02 accepts AT-command from UART port and change the configuration; in Transparent mode, ALL data from UART port will forward to Bluetooth and vice versa.

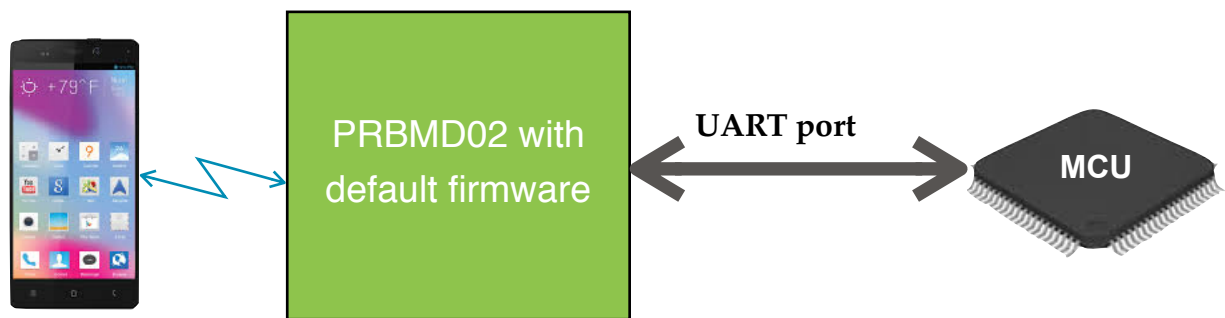

data from BLE appears on UART_TX pin automatically

data sent to UART_RX pin will automatically forward to BLE side

TRANSPARENT mode description

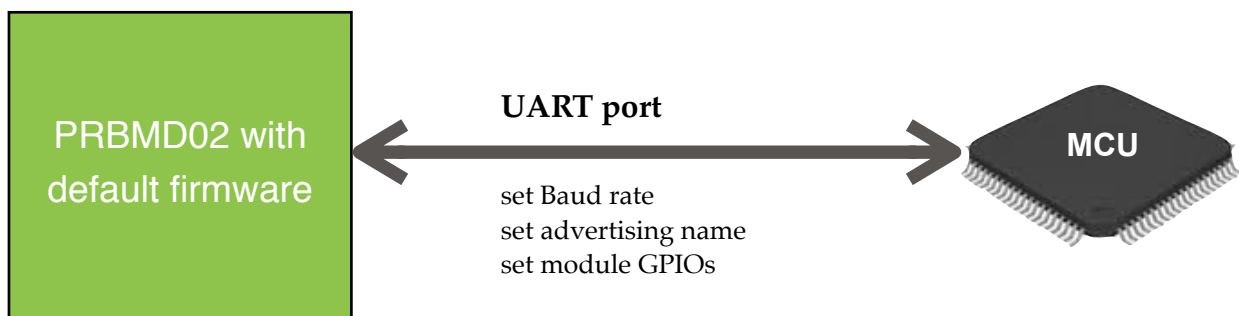

AT-CMD mode description

Mode switching

The switching between AT-CMD and Transparent mode is automatically. When PRBMD02 is NOT connected with smartphone, tablet..., PRBMD02 will enter AT-CMD mode and AT-command will be accepted from UART port; and once PRBMD02 is connected to with smartphone or any other BT device, PRBMD02 will automatically go into Transparent mode, and all data from UART, even AT-CMD, will be treated as data and send out to BT side. The operation is illustrated as following:

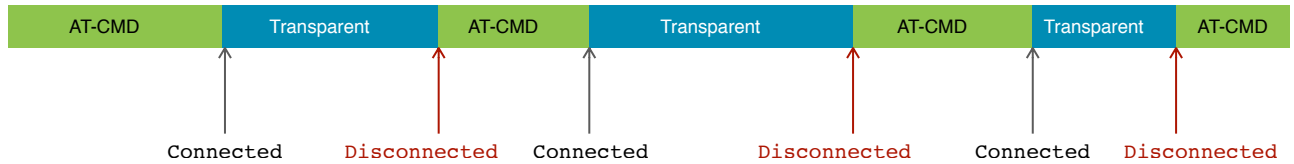

Pin definition

The PRBMD02 default firmware mainly defined some pins of PRBMD02 as following:

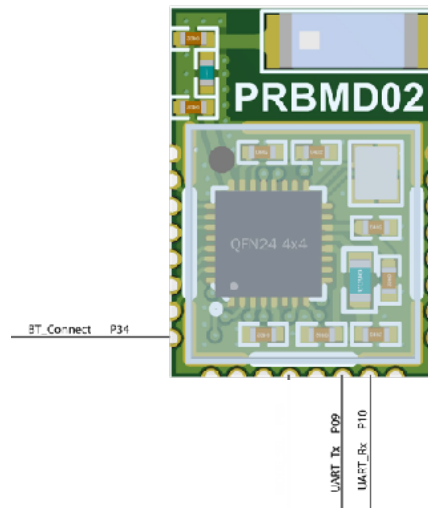

Pin assignment in PRBMD02

P34: BT_Connect, it is used to connect with LED to indicate the BT connection status. Before connection, this pin will toggle at about 2Hz frequency, and after a connection is established, this pin will turn to LOW status

P09: UART_Tx, Firmware define it as Tx pin of UART, which is supposed to be connect to UART Rx pin of MCU or other device.

P10: UART_Rx, Firmware define it as Rx pin of UART, which is supposed to be connect to UART Tx pin of MCU or other device.

AT-command

AT-command in AT-CMD mode are listed as below:

	Action	enquiry	return value	set	return value
BT related	set/get ID	AT+ID?	Current address	AT+ID=addr addr format: xx:xx:xx:xx:xx:xx	
	Help	AT+HELP	List all AT commands and status		
	Reset			AT+RESET	
	Factory Default setting (reset needed)			AT+DEFAULT	- BAUD = 115200, TXP = 0, NAME = PRBMD02
	Change name	AT+NAME?	- current name Default:PRBMD02	AT+NAME= New name	
	Start advertising			AT+BDCS	
	Stop advertising			AT+BDCE	
	Get/Set Tx power level	AT+TXP?	0-4 0: 5dBm 1: 0dBm 2: -5dBm 3: -20dBm 4: -10dBm	AT+TXP=y y= 0-4	
UART and GPIO	BAUD rate	AT+SPEED?	Current baud	AT+SPEED=BAUD , BAUD = 4800, 9600, 14400, 19200, 38400,57600, 115200 and 5000000	- New BAUD if success note: data byte, parity and stop bit are fixed at 8,N,1
	Define a pin as BT_Connect LED pin			AT+LED=xx , xx=GPIO	
	Enable BT_Connect LED			AT+LEDON	
	Disable BT_Connect LED			AT+LEDOFF	
	Read and set IO pin (except P09 and P10)	AT+GPIOxx=? xx:available GPIO	1 or 0	AT+GPIOxx=y xx:available GPIO	y= 0 or 1, where 0 is low level and 1 is high level
	All GPIO HIGH			AT+HIGH	
	All GPIO LOW			AT+LOW	

Firmware programming

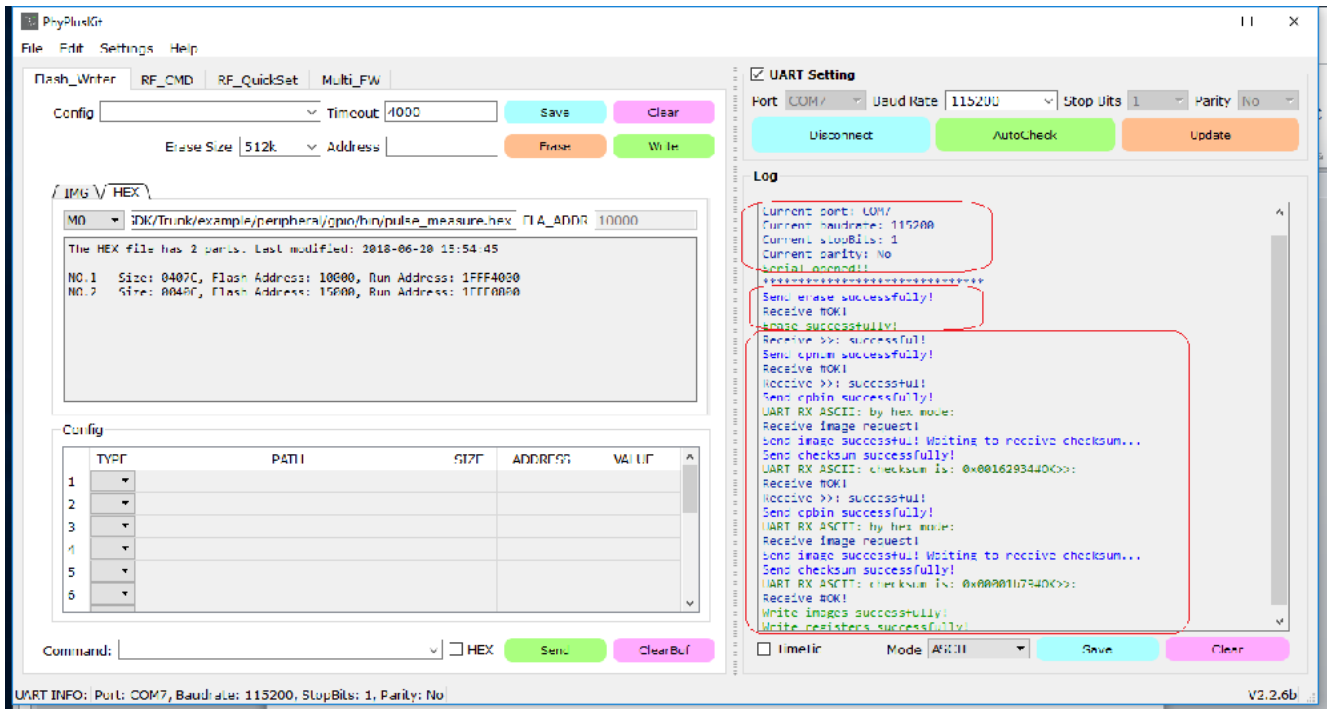
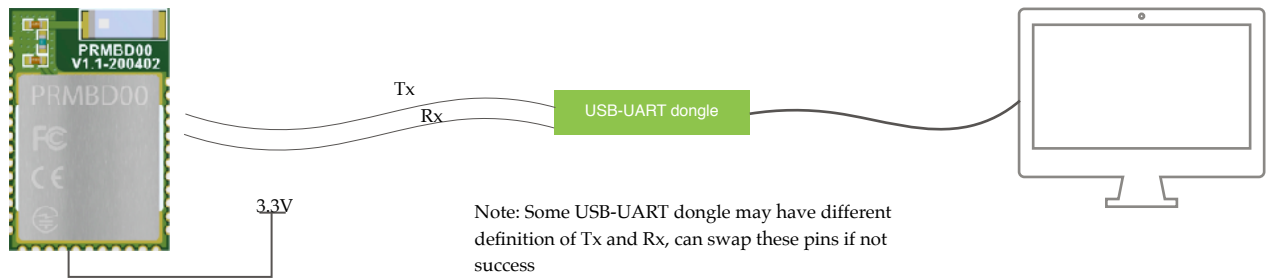

PhyPlusKit interface

Note: More information will be described in PRBMD0x Programming document.

MAC address

Unless otherwise instructed, each PRBMD02 will be shipped with KATP pre-programmed but no MAC address is pre-programmed. User can program their own MAC address by PhyPlusKit. It is important to be reminded that *MAC address can be only written once and cannot be re-written.*

	TYPE	PATH	SIZE	ADDRESS	VALUE
1	MAC				56:78:90:98:76:54
2					
3					
4					

Mounting guide

PRBMD02 is RF sensitive; in order to obtain the best performance, it is recommended to mount the module at corner of mother board, and with some marginal space.

Also, keep it away from metal components, such like speakers, transformers, batteries, big aluminum capacitors, heat sinks and Metal Panels.

The figure below illustrates how to mount the PRBMD02 module. Improper mounting will decrease the RF performance dramatically.

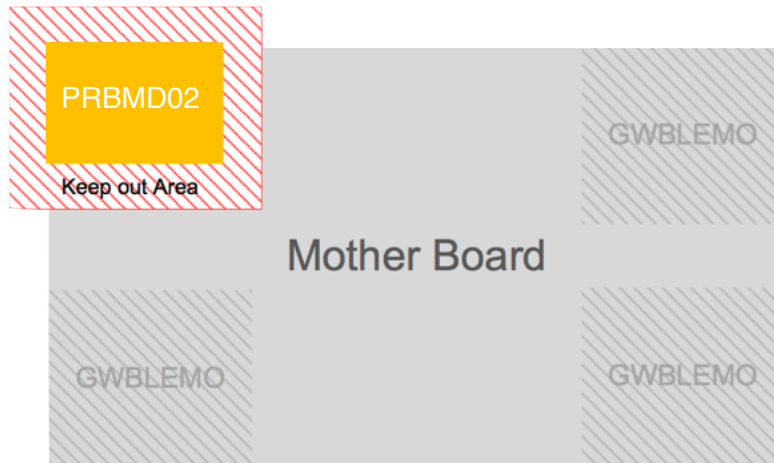

Evaluation Board

Evaluation board (EVB) is available, helping engineer for the firmware development. It is in DIP form factor, allows engineer to connect with external circuit easily for debugging and testing. EVB for PRBMD02 is same as EVB for PRBMD00, and an adaptor board that convert PRBMD02 pin to connect with the EVB

The EVB is illustrated as following:

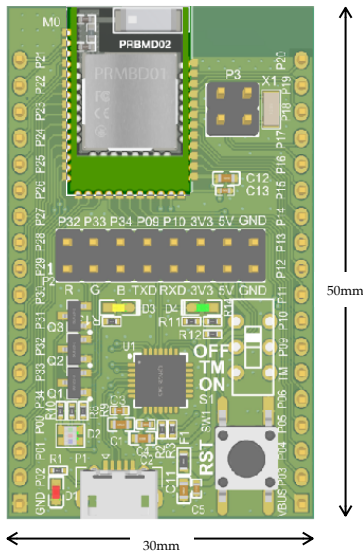

PRBMD02 on adaptor board

The EVK is in DIP format with PRBMD02 (and adaptor board) on it, and with on board 32.768KHz crystal and UART-USB chip, allow user to test and program the module easily. PRBMD02 is pre-programmed with the UART-BT tunnelling firmware. Below is the block diagram of the EVK:

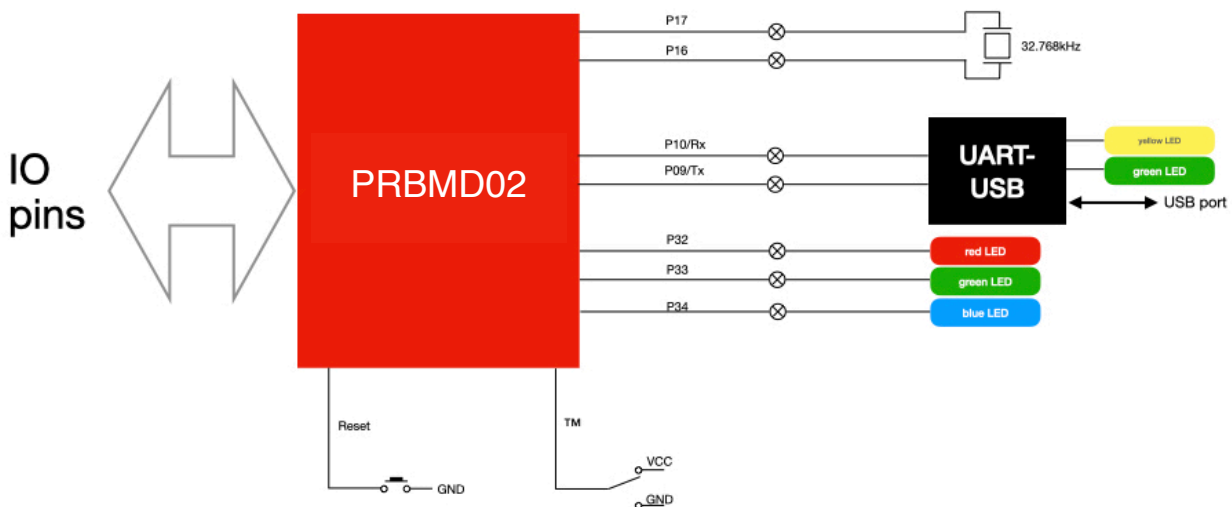

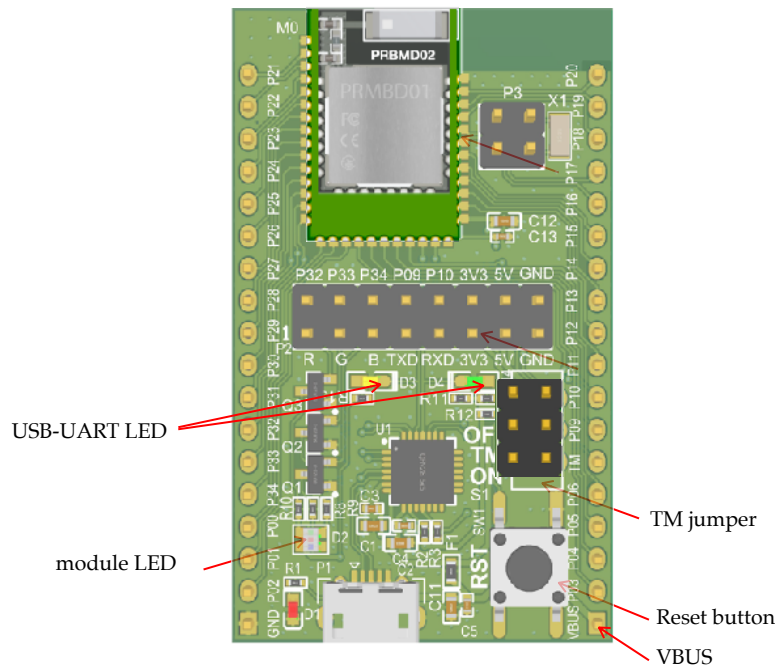

1. 32K jumper:

Since P16,P17 are multiplex with external 32.768KHZ oscillator, this jumper allows the PRBMD02 to connected with the on board 32.768KHZ oscillator.

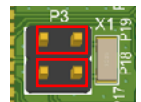

2. LED & UART jumper:

This jumper allows the module to connected with on-board LED and the on-board USB-UART chip. Connecting 5V allow PRBMD02 to be powered from USB. Connecting 3V3 will provides a 3.3VDC to the rest of the board



3. TM Jumper

PRBMD02 goes into firmware programming mode if TM pin is connected to the 3V3 pin.

4. Reset button

Pressing this button to reset PRBMD02 module

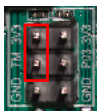

5. USB-UART LED:

LEDs indicate UART traffic, yellow LED represents TXD and green LED represents RXD

6. module LED:

LEDs connect to the LED & UART jumper, user can makes use of these LED by shorting the jumper.

7. VBus pin:

The EVK can be powered by USB port, or a 5VDC can be applied to this pin to power up the board.

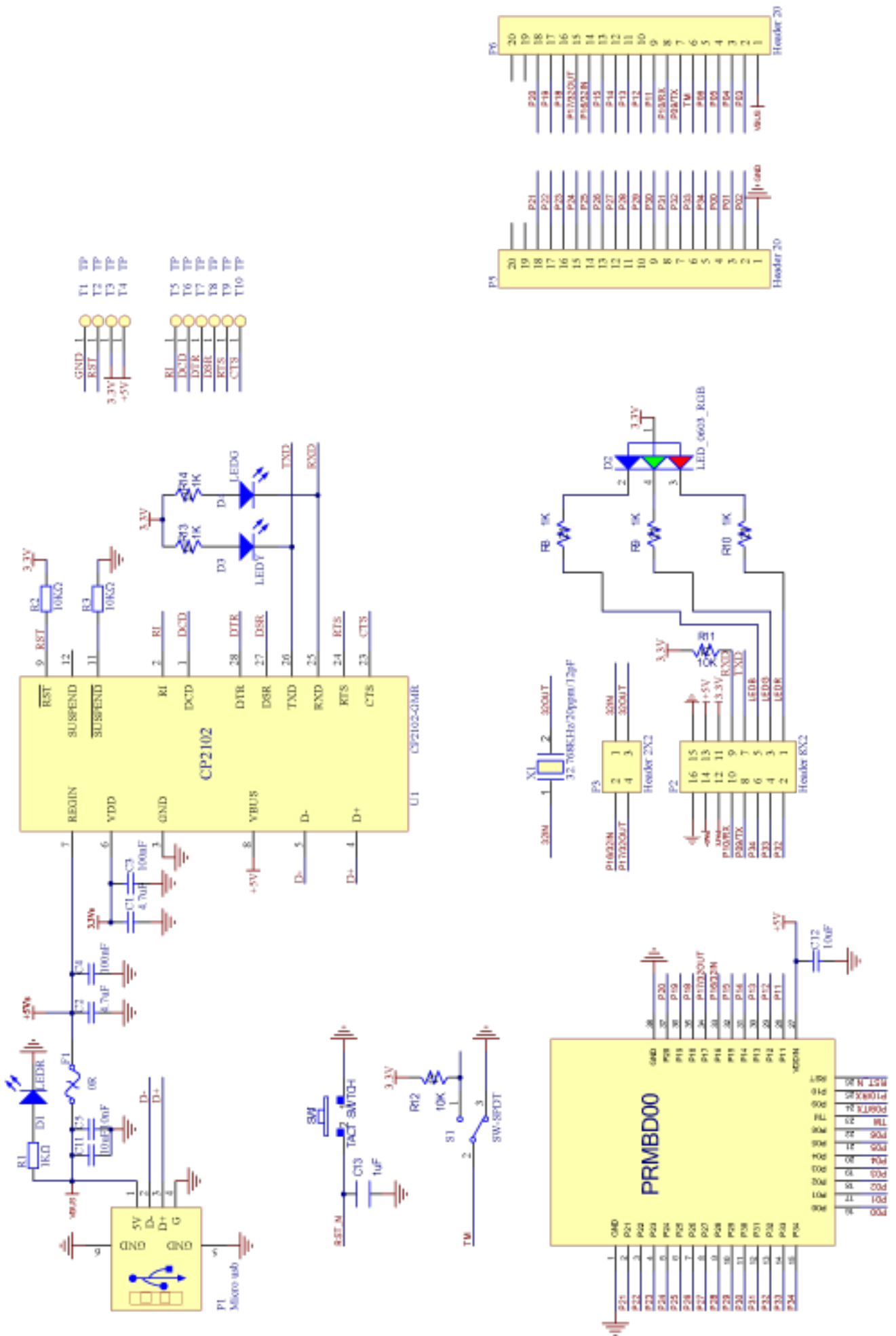

Firmware development and SDK

User is allowed to developed their own firmware for PRBMD02 through SDK as following:

1. copy SDK to a working directory
2. install MDK Keil5 for ARM IDE
3. Example code in SDK can now be edit and compiled.

Experience on ARM core firmware development will be very helpful for development the firmware.

The SDK for PRBMD02 including the following resource:

PHY62XXSDK	
components	; SDK components, including BLE API, GATT profile, drivers and other components
example	; example
ble_central	;
ble_peripheral	;
alternate_iBeacon	; alternate iBeacon example
ancs	; Apple Notification Center Service example
bleI2C_RawPass	; I2S tunnelling example
bleSmartPeripheral	; General peripheral example
bleUart-RawPass	; UART tunnelling example
eddystone	; eddystone example
HIDKeyboard	; HID example
hrs	; Heart rate profile example
iBeacon	; iBeacon example
otaDemo	; Basic OTA example
pwmLight	; example of LED control by PWM, by BLE command
RawAdv	; simple boardcasting example, for tire pressure monitor
Sensor_Broadcast	;
wrist	; General example for sport bracelet
wrist_aptm	; General example, real time timer base on AP Timer + OSAL Timer
XIPDemo	; Example of running within flash, for application not requiring realtime response
OTA	;
OTA_internal_flash	; OTA bootloader
OTA_upgrade_2ndboot	; Special example for upgrading OTA bootloader
peripheral	;
adc	; ADC driver example
ap_timer	; AP timer driving example
fs	; File system example
gpio	; GPIO demo example
kscan	; 4x4 keypad example
lcd_ST7789VW	; 240x240 TFT display example
pwm	; PWM demo example
qdec	; QDEC demo example
spiflash	; SPI ext. device example
voice	; Audio sampling example
voice_sbc	; SBC coding format audio sampling example
watchdog	; Watchdog example
lib	; lib and .h document, including Bluetooth stack and Font library
font	; Font resource document
misc	; ROM symbol table and others

Note: SDK for PRBMD02 (PHY6222 core) is different from the SDK for PRBMD00 (PHY6212 core).

Service

Firmware programming

K-Solution provide pre-programming service, so that PRBMD02 will be shipped with firmware pre-programmed. Service charge is needed.

Software service from K-Solution

K-Solution also provides firmware develop service for PRBMD02 module, hence customer do not need to spend their resource on the firmware development.

These services requires NRE charge. For the details, please contact our local sales representative or distributor.

Hardware design service

K-Solution can also provide circuit design service base on PRBMD02, so that customer can simply focus on the ID of their product.

Circuit board production service

With our partners factory, K-Solution is able to provide SMT-ed PCB with PRBMD02 to customers, and helping customer the assembly their products.

Certification service

K-Solution could introduce our partnered test lab to customer for their product certification, where K-Solution could facilitate the process.

Certifications

to be updated

Ordering part number

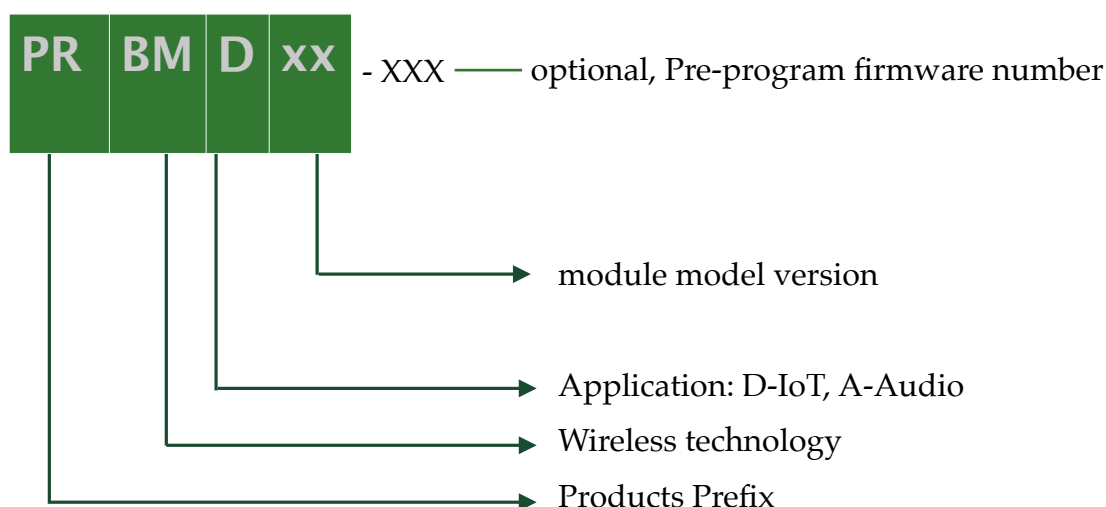

Available part number:

PRBMD00 - PHY6212 core BT5 module, on board chip antenna, 38 pins, 12 x 18 mm, standard UART firmware, chip antenna, metal shielding and certifications

PRBMD01 - PHY6212 core BT5 module, on board chip antenna, 24 pins, 10 x 14 mm standard UART firmware, chip antenna, no metal shielding and no certification

PRBMD02 - PHY6222 core BT5 module, 10 x 14 mm, standard UART firmware, chip antenna, metal shielding and certifications

PRBMD03 - PHY6222 core BT5 module, 10 x 14 mm, standard UART firmware, chip antenna, without metal shielding nor certifications

PRBMD12 - PHY6222 core BT5 module, 10 x 14 mm, standard UART firmware, PCB antenna.

PRBMDEVK - Evaluation board with PRBMD00 on board

Label

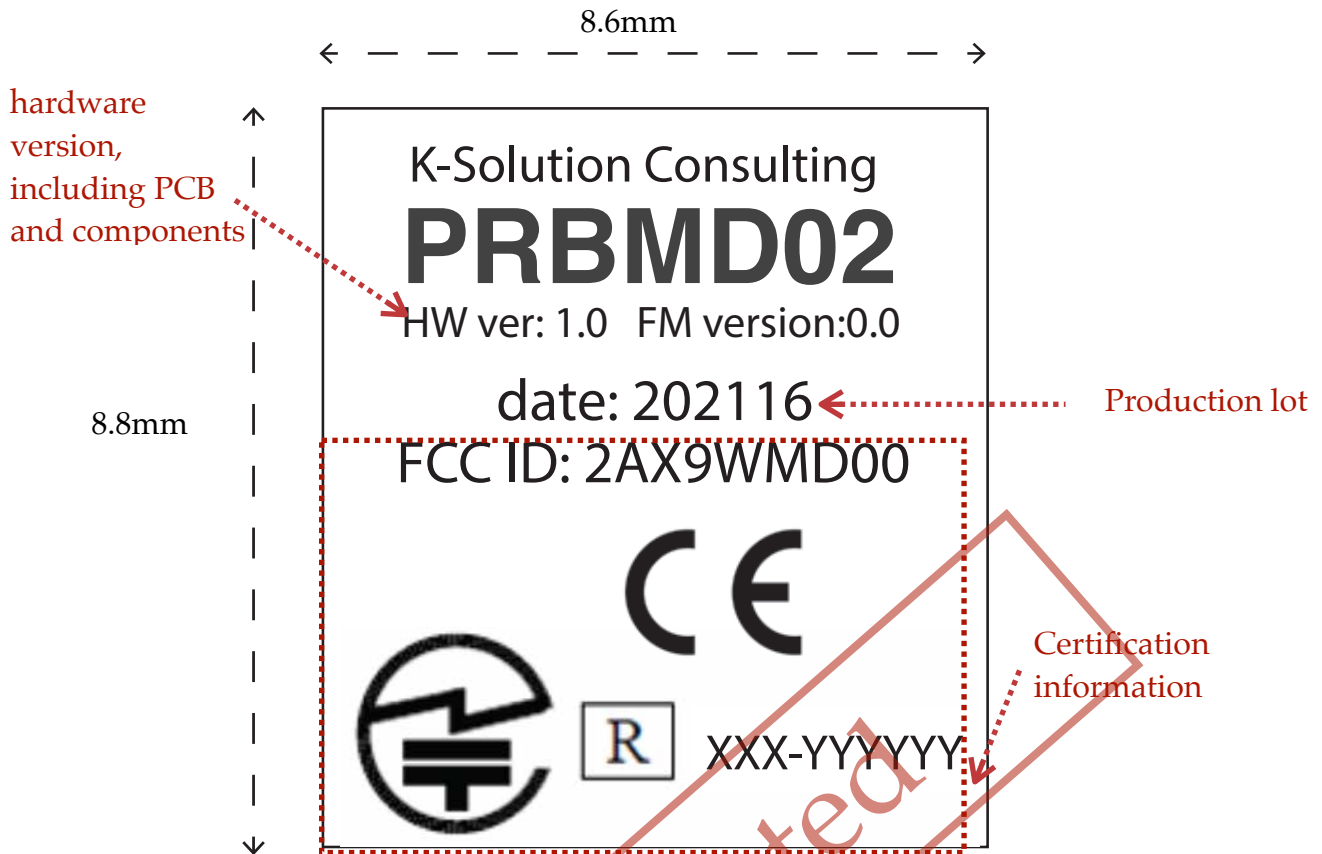

Note: label design may be update and modified if needed

To be updated

Conformity

FCC regulatory conformance :

This device complies with Part 15 of the FCC Rules. Operation is subject to the following two conditions:

- (1) This device may not cause harmful interference.
- (2) This device must accept any interference received, including interference that may cause undesired operation.

NOTE: This equipment has been tested and found to comply with the limits for a Class B digital device, pursuant to part 15 of the FCC Rules. These limits are designed to provide reasonable protection against harmful interference in a residential installation.

This equipment generates uses and can radiate radio frequency energy and, if not installed and used in accordance with the instructions, may cause harmful interference to radio communications. However, there is no guarantee that interference will not occur in a particular installation. If this equipment does cause harmful interference to radio or television reception, which can be determined by turning the equipment off and on, the user is encouraged to try to correct the interference by one or more of the following measures:

- Reorient or relocate the receiving antenna.
- Increase the separation between the equipment and receiver.
- Connect the equipment into an outlet on a circuit different from that to which the receiver is connected.
- Consult the dealer or an experienced radio/TV technician for help

NOTE: The manufacturer is not responsible for any radio or TV interference caused by unauthorized modifications to this equipment. Such modifications could void the user's authority to operate the equipment.

RF Exposure

This equipment complies with FCC radiation exposure limits set forth for an uncontrolled environment.

ORIGINAL EQUIPMENT MANUFACTURER (OEM) NOTES

The OEM must certify the final end product to comply with unintentional radiators (FCC Sections 15.107 and 15.109) before declaring compliance of the final product to Part 15 of the FCC rules and regulations. Integration into devices that are directly or indirectly connected to AC lines must add with Class II Permissive Change.

The OEM must comply with the FCC labeling requirements. If the module's label is not visible when installed, then an additional permanent label must be applied on the outside of the finished product which states: "Contains transmitter module FCC ID: **2AX9WMD00**". Additionally, the following statement should be included on the label and in the final product's user manual: "This device complies with Part 15 of the FCC Rules. Operation is subject to the following two conditions:

- (1) This device may not cause harmful interferences, and
- (2) this device must accept any interference received, including interference that may cause undesired operation."

The module is limited to installation in mobile or fixed applications. Separate approval is required for all other operating configurations, including portable configuration with respect to Part 2.1093 and different antenna configurations.

A module or modules can only be used without additional authorizations if they have been tested and granted under the same intended end - use operational conditions, including simultaneous transmission operations. When they have not been tested and granted in this manner, additional testing and/or FCC application filing may be required. The most straightforward approach to address additional testing conditions is to have the grantee responsible for the certification of at least one of the modules submit a permissive change application. When having a module grantee file a permissive change is not practical or feasible, the following guidance provides some additional options for host manufacturers. Integrations using modules where additional testing and/or FCC application filing(s) may be required are: (A) a module used in devices requiring additional RF exposure compliance information (e.g., MPE evaluation or SAR testing); (B) limited and/or split modules not meeting all of the module requirements; and (C) simultaneous transmissions for independent collocated transmitters not previously granted together.

This Module is full modular approval, it is limited to OEM installation ONLY.

Integration into devices that are directly or indirectly connected to AC lines must add with Class II Permissive Change. (OEM) Integrator has to assure compliance of the entire end product include the integrated Module. Additional measurements (15B) and/or equipment authorizations (e.g. Verification) may need to be addressed depending on co-location or simultaneous transmission issues if applicable. (OEM) Integrator is reminded to assure that these installation instructions will not be made available to the end user

Operating Frequency : (Bluetooth LE) 2402-2480MHz
RF output power(Max) : 4dBm

Manufacturer information:

Company name: K-Solution Consulting Co. Ltd

Address : Blk. H, 11/f, Yuet Wah mansion, 39 Yuet Wah street, KwunTong, HK

CAUTION :

1. EUT Temperature: 0°C ~ +50°C.
2. Input: DC 3.3V
3. The device complies with RF specifications when the device used at 5 mm from your body, and the holder must not be of metal composition.

RF exposure information: The EIRP power of the device at maximal case is below the exempt condition, 20mW specified in EN62479: 2010. RF exposure assessment has been performed to prove that this unit will not generate the harmful EM emission above the reference level as specified in EC Council Recommendation(1999/519/EC).

Hereby, K-Solution Consulting Co. Ltd. declares that the radio equipment type PRBMD02 is in compliance with Directive 2014/53/EU. The full text of the EU declaration of conformity is available at the following internet address: www.k-sol.com.hk

Ordering part number

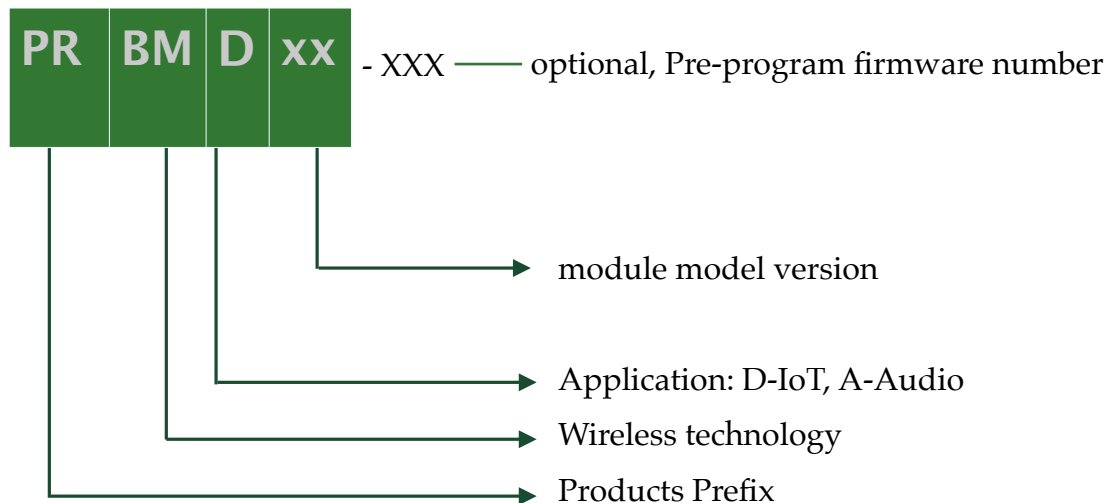

Available part number:

PRBMD02 - PHY6222 core BT5 module, on board chip antenna, 38 pins, 12 x 18 mm, standard UART firmware, chip antenna, metal shielding and certifications

PRBMD01 - PHY6222 core BT5 module, on board chip antenna, 24 pins, 10 x 14 mm standard UART firmware, chip antenna, no metal shielding and no certification

PRBMD02 - PHY6222 core BT5 module, 10 x 14 mm, standard UART firmware, chip antenna, metal shielding and certifications

PRBMD12 - PHY6222 core BT5 module, 10 x 14 mm, standard UART firmware, PCB antenna.

PRBMDEVK - Evaluation board with PRBMD01 on board

PRBMDEVK2 - Evaluation board with PRBMD02 on board

Package

Standard package of PRBMD02 is anti-electro static plastic tray, where each tray should be able to contain xx pcs PRBMD02. Dimension of each tray is xxxx mm.

To be updated

Note: package format is subject to change in order to enhance the efficiency

PRBMD0x comparison

	PRBMD00	PRBMD01	PRBMD02	PRBMD03	PRBMD12
Core chip	PHY6212	PHY6212	PHY6222	PHY6222	PHY6222
MCU core	M0	M0	M0	M0	M0
RAM (Byte)	138K	138K	64K	64K	64K
FLASH (Byte)	512K	512K	128K	128K	128K
Cache (Byte)	0	0	8K	8K	8K
SDK	available	available	available	available	available
BT ver	5.1	5.1	5.1	5.1	5.1
Metal shielding	✓	✗	✓	✓	✗
MESH	✓	✓	✓	✓	✓
Audio	✓	✗	✗	✗	✗
GPIO	33	19	19	19	19
Antenna	chip	chip	chip	chip	PCB
32768Hz OSC	external	external	external	external	external
main clock	16MHz	16MHz	16MHz	16MHz	16MHz
Tx power max	10dBm	10dBm	10dBm	10dBm	10dBm
Sensitivity @1M	-97dBm	-97dBm	-97dBm	-97dBm	-97dBm
Operating current	670uA	670uA	460uA	460uA	460uA
Idle current	0.7uA	0.7uA	0.3uA	0.3uA	0.3uA
Operating voltage	3.3-6V	1.8-3.6V	1.8-3.6V	1.8-3.6V	1.8-3.6V
Certification	FCC, CE, TELEC	N/A	FCC, CE, TELEC	N/A no shielding	TBC
Status	in production	Build-to-order	designing	designing	planning

Revision History

2021-03-02	version 0.5
2021-12-16	version 0.9

Reference

ADC Application Note
ANCS Application Note
Font Application Note
GPIO Application Note
OTA Note
SDK Application Guide
MESH Application Guide
KATP product brief

Contact information

Head quarter:

K-Solution Consulting Co. Ltd.

web: www.k-sol.com.hk

Tel: +852-91983405

Fax: +852 3013 8763

E-mail: sales@k-sol.com.hk